

Guitar Fingerboard - Modes in C major

C major - Phrygian position (iii)

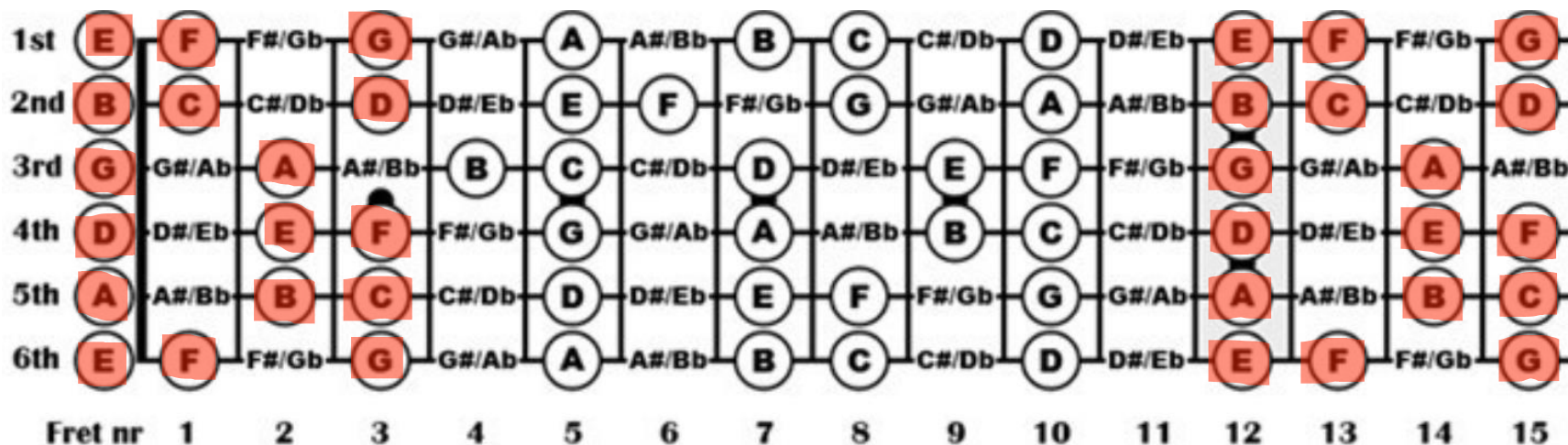

C major - Lydian Position (IV)

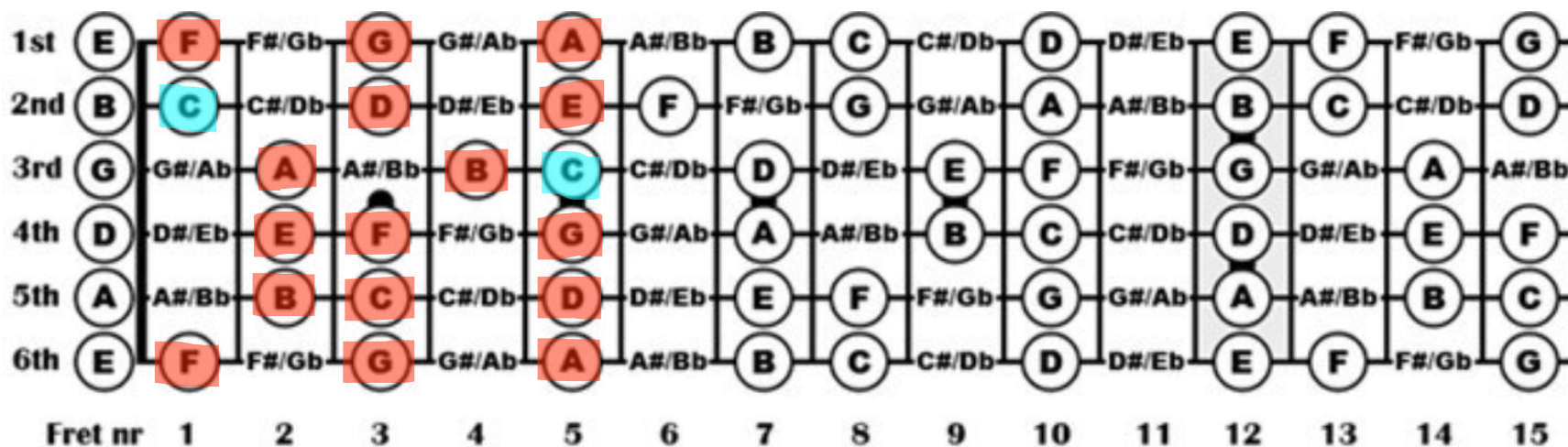

C major - Mixolydian Position (V)

transitory pattern between Phrygian and Locrian positions

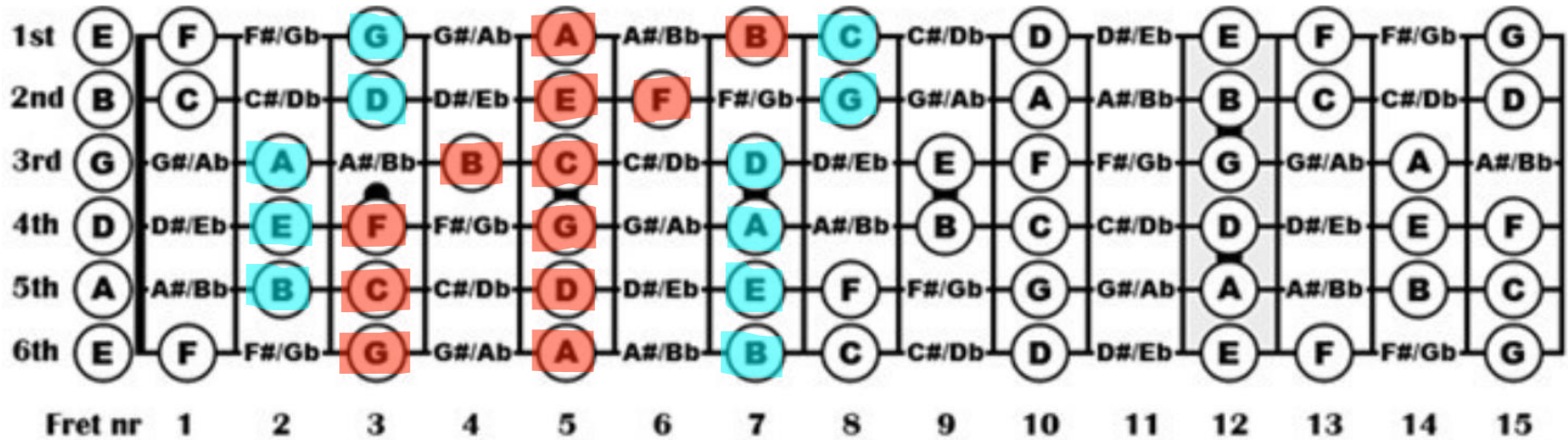

C major - Aeolian Position (vi)

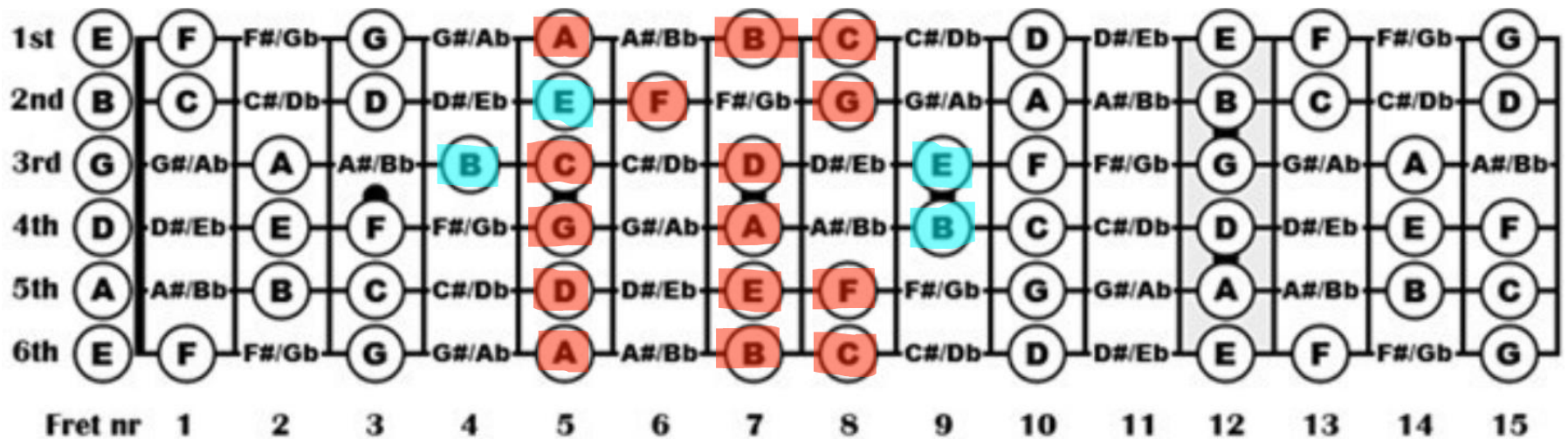

C major - Locrian position (vii^o)

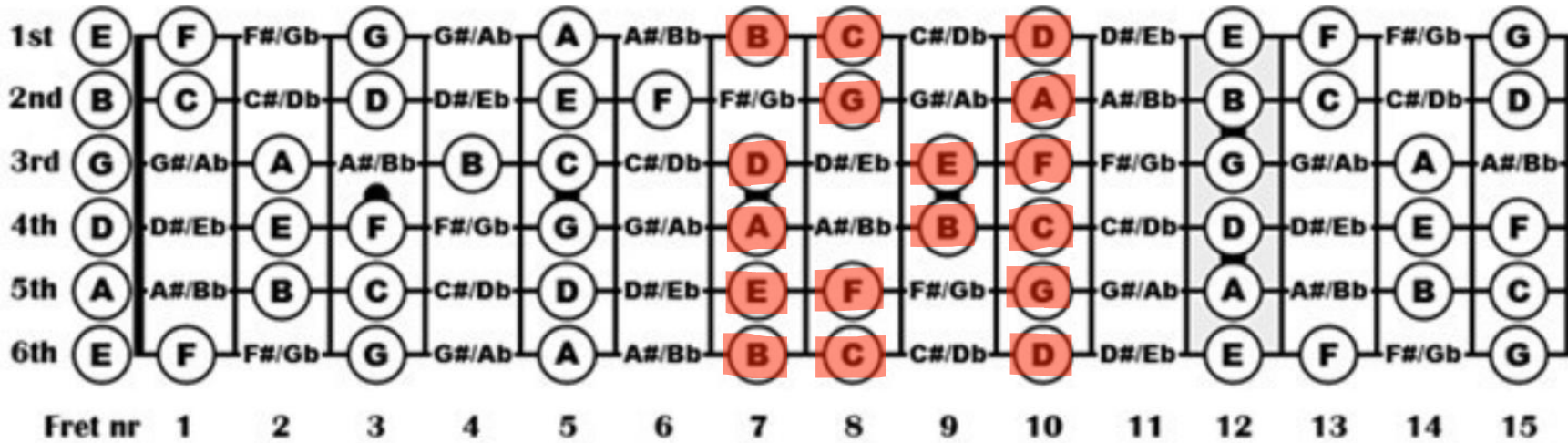

C major - Ionian position (I) C

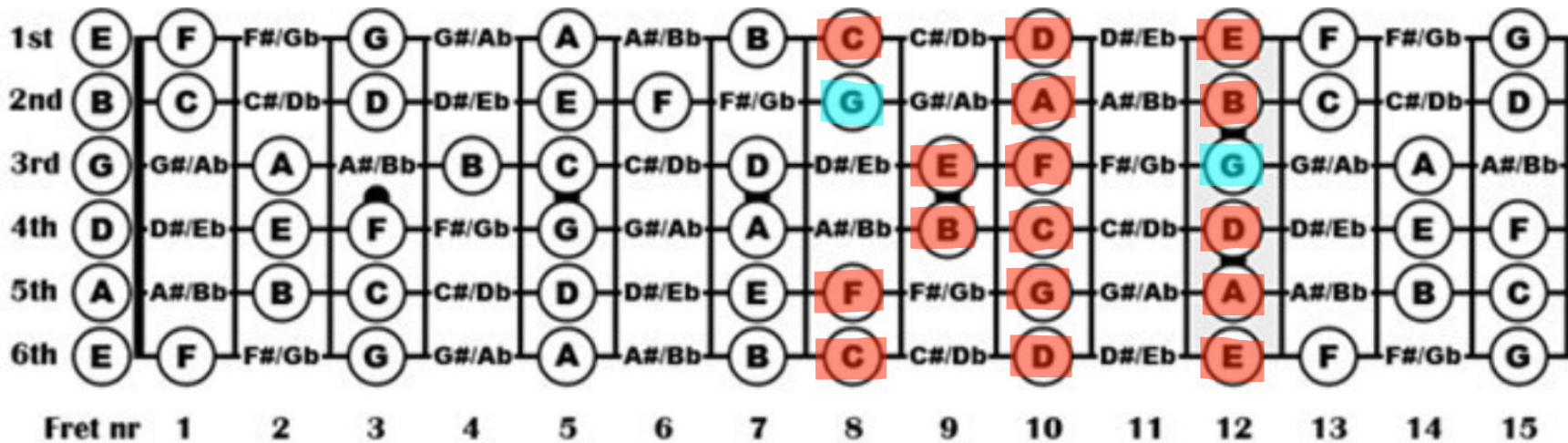

C major - Dorian position (ii)

